

KEGERATOR BAR COOLER WITH BEER DISPENSER TAPS

SKU: 12000-795 | 16000-200 | 16000-339 | 12000-792 | 12000-794 | 12000-791 | 12000-793



12000-795
with casters



16000-200/
16000-339



12000-792



12000-794



12000-791



12000-793

Enjoy a cold, fresh pour of favorite brew at the perfect temperature.

Designed with enduring quality and value. The exterior comprises of attractive corrosion resistant vinyl on steel in black finish. Durable stainless steel top, interior walls, floor and ceiling. Self-closing doors with locks. It comes with LED lights.

FEATURES:

- Efficient Cooling Technology**
 Uses Hydro-Carbon R290 providing the optimal performance of the cooler, delivering product temperature ideal for consumption.
- Durable Construction**
 Built with high-quality materials, ensuring long-lasting durability and reliable performance.
- Self-Closing Doors with Locks**
 Automatically closes, preserving the cold temperature inside and saving energy.
- Sleek Design with LED interior Lighting**
 Exterior construction is attractive corrosion resistant vinyl on steel in black finish.

- Removable Installation Board**
 Makes it easy to access condenser coil for cleaning and service
- Adjustable Shelves**
 Provides versatility in arrangement and optimizing space within the warmer.

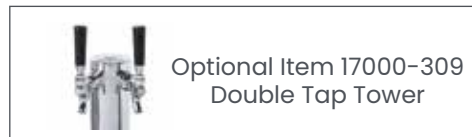

Optional Item 17000-309
Double Tap Tower



Stainless steel
top tray cover



Thermometer



Mechanical
Temperature Controller

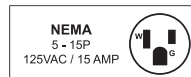



TECHNICAL SPECIFICATION

Features	24" wide with 6.5 cu.ft. capacity & casters	49" wide with 11.8 cu.ft. capacity	59" wide with 19.3 cu.ft. capacity	61" wide with 15.8 cu.ft. capacity
Item	12000-795	16000-200	16000-339	12000-792
Capacity	6.5 cu.ft. / 170 L	11.8 cu.ft. / 335 L	19.3 cu.ft. / 546.5 L	15.8 cu.ft. / 446 L
Product Capacity	1 keg (half-barrel)	2 kegs (half-barrel)	2 kegs (half-barrel)	3 kegs (half-barrel)
Number of Doors	1 Swing Door	2 Swing Doors	2 Swing Doors	2 Swing Doors
Number of Shelves	-	4	4	4
Number of Casters	4	-	-	-
Power	1/6 HP	1/5 HP	1/5 HP	1/5 HP
Amps	1.92 A	3 A	2.88 A	3 A
Electrical	115V / 60Hz / 1Ph	115V / 60Hz / 1Ph	115V / 60Hz / 1Ph	115V / 60Hz / 1Ph
Temperature Controller	Mechanical	Mechanical	Mechanical	Mechanical
Temperature Range	5 to 0.5°C / 41 to 33°F	5 to 0.5°C / 41 to 33°F	5 to 0.5°C / 41 to 33°F	5 to 0.5°C / 41 to 33°F
Refrigerant	R290	R290	R290	R290
Interior Dimensions (WDH)	19.5" x 18" x 29" / 495 x 457 x 737 mm	36" x 18.5" x 29" / 914x 467 x 737 mm	46" x 22" x 29" / 1168 x 559 x 737 mm	48" x 18.5" x 29" / 1219 x 467 x 737 mm
Net Weight	132.28 lb. / 60 kg.	231.49 lb. / 105 kg.	279 lb. / 127 kg.	275.58 lb. / 125 kg.
Net Dimensions (WDH)	23.5" x 30.8" x 51.5" / 597 x 782x 1308 mm	48.8" x 24.4" x 51.5" / 1240 x 620 x 1308 mm	58.8" x 27.7" x 45.5" / 1494 x 704 x 1156 mm	60.8" x 24" x 51.5" / 1544 x 610 x 1308 mm
Gross Weight	169 lb. / 76.7 kg.	319 lb. / 114.7 kg.	312 lb. / 142 kg.	319 lb. / 114.7 kg.
Gross Dimensions (WDH)	25.2" x 32" x 48" / 640 x 813 x 1219 mm	63" x 27" x 42" / 1600 x 686 x 1067 mm	61.3" x 30.5" x 42" / 1549 x 775 x 1067 mm	63" x 27" x 42" / 1600 x 686 x 1067 mm
Plug Type	NEMA 5 - 15P	NEMA 5 - 15P	NEMA 5 - 15P	NEMA 5 - 15P

12000-794



12000-791



12000-793



TECHNICAL SPECIFICATION			
Features	69" wide with 23.3 cu.ft. capacity	73" wide with 19.6 cu.ft. capacity	90" wide with 32 cu.ft. capacity
Item	12000-794	12000-791	12000-793
Capacity	23.3 cu.ft. / 659.7 L	19.6 cu.ft. / 556 L	32 cu.ft. / 916 L
Product Capacity	3 kegs (half-barrel)	3 kegs (half-barrel)	5 kegs (half-barrel)
Number of Doors	2 Swing Doors	3 Swing Doors	3 Swing Doors
Number of Shelves	4	6	6
Number of Casters	-	-	-
Power	1/5 hp	1/4 hp	1/4 hp
Amps	3.6 A	4 A	4.7A
Electrical	115V / 60Hz / 1Ph	115V / 60Hz / 1Ph	115V / 60Hz / 1Ph
Temperature Controller	Mechanical	Mechanical	Mechanical
Temperature Range	5 to 0.5°C / 41 to 33°F	5 to 0.5°C / 41 to 33°F	5 to 0.5°C / 41 to 33°F
Refrigerant	R290	R290	R290
Interior Dimensions (WDH)	56.5" x 21.8" x 29" / 1435 x 557 x 737 mm	60.2" x 18.5" x 29" / 1529x 467x 737 mm	77.5" x 21.8" x 29" / 1969 x 554 x 737 mm
Net Weight	326 lb. / 148 kg.	331 lb. / 150 kg.	374 lb. / 170 kg.
Net Dimensions (WDH)	69" x 27.8" x 48.4" / 1753 x 706 x 1229 mm	72.8" x 24" x 51.5" / 1849 x 610 x 1308 mm	90.4" x 27.7" x 48.4" / 1849 x 610 x 1308 mm
Gross Weight	327 lb. / 148.3 kg.	385 lb. / 175 kg.	398 lb. / 180.5 kg.
Gross Dimensions (WDH)	71" x 30" x 41" / 1803 x 762 x 1041 mm	75" x 27" x 42" / 1905 x 686 x 1067 mm	92" x 31" x 43" / 2337 x 787 x 1092 mm
Plug Type	NEMA 5 - 15P	NEMA 5 - 15P	NEMA 5 - 15P

TECHNICAL DRAWING

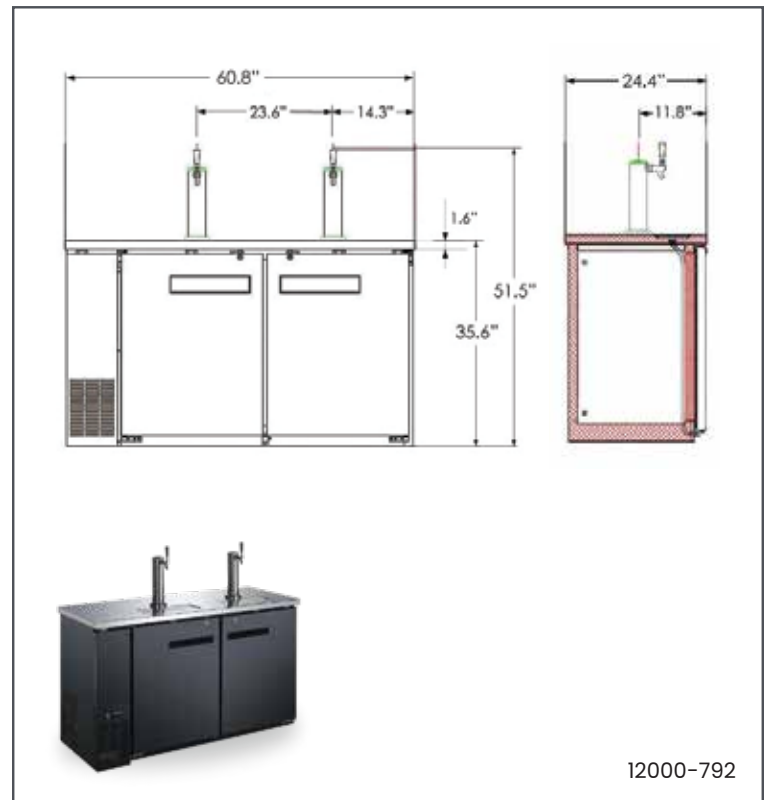
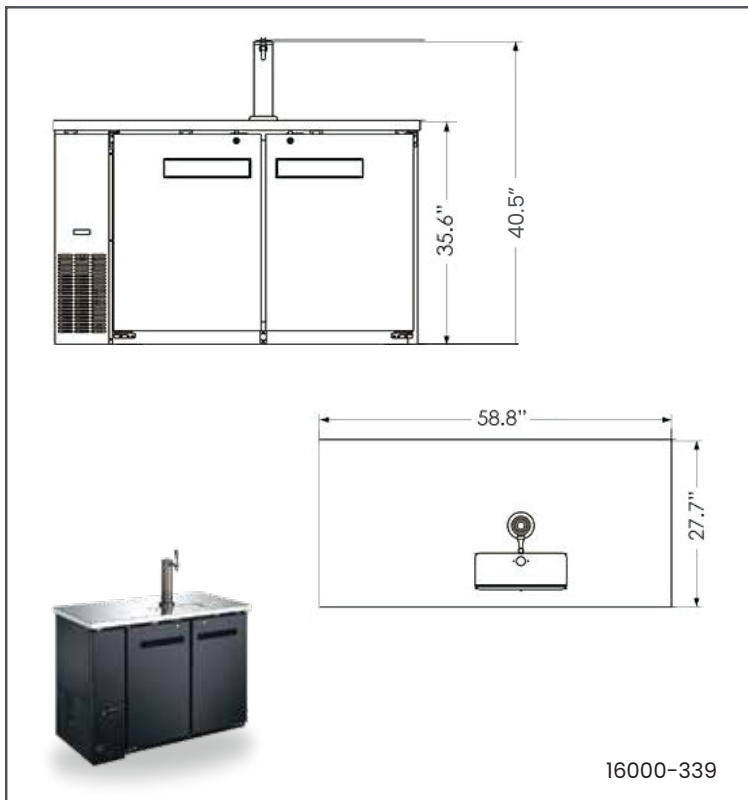
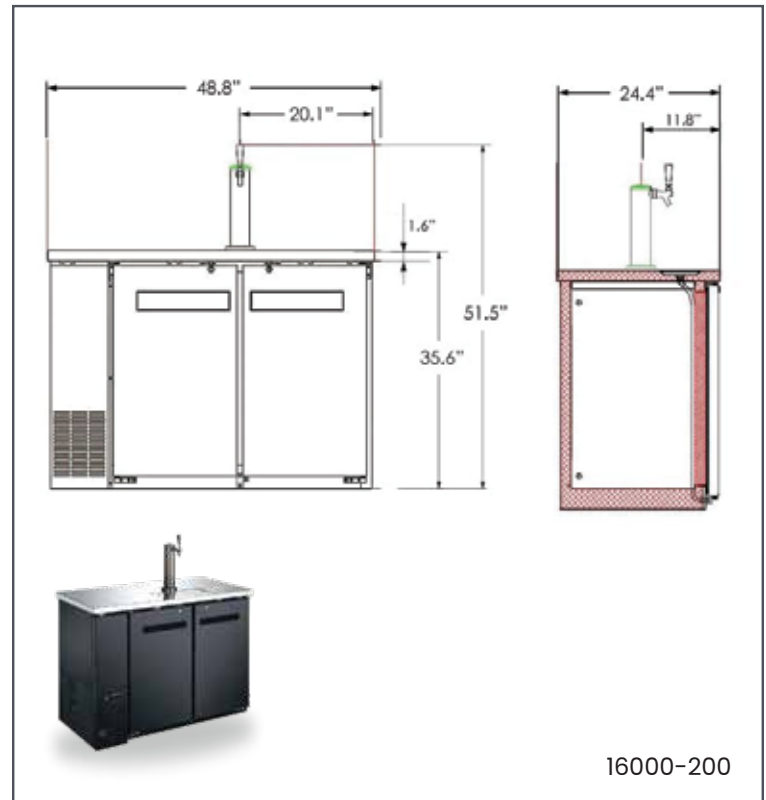
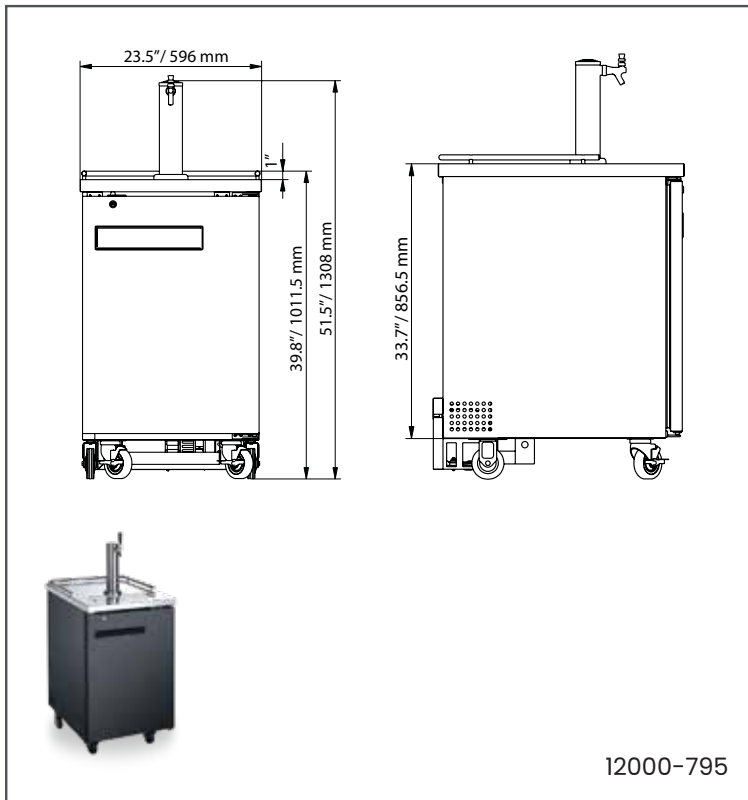

TECHNICAL DRAWING

